

Type I Crossovers

New Design

Learn the features and benefits of our new step over design

Single and Double Conveyor Options Available

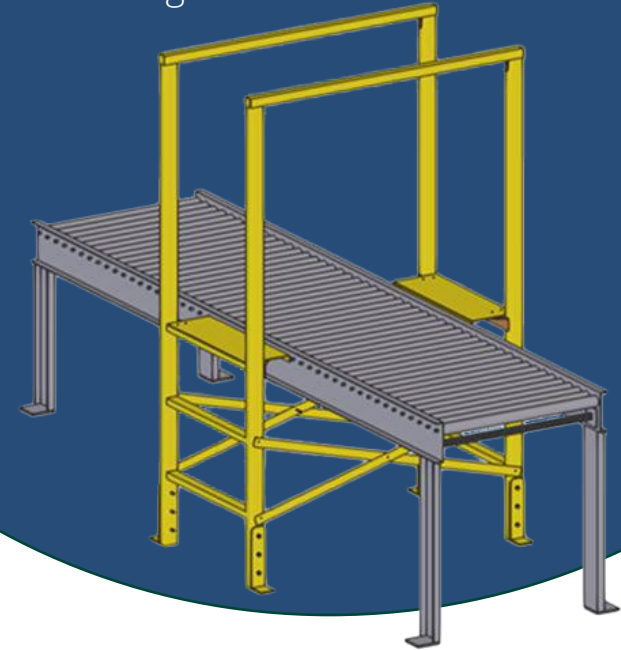

Efficient Design

- Used market-driven insights to standardize components
- See page 2 for specifications



Competitive Pricing

- Innovative design enabled lower pricing without sacrificing quality
- Contact your sales rep for more information



Quicker Turnaround

- Lead time reduced from months to 1-2 weeks
- Avoids costly delays on these often-last-minute items

Type I Crossover Specifications

Single

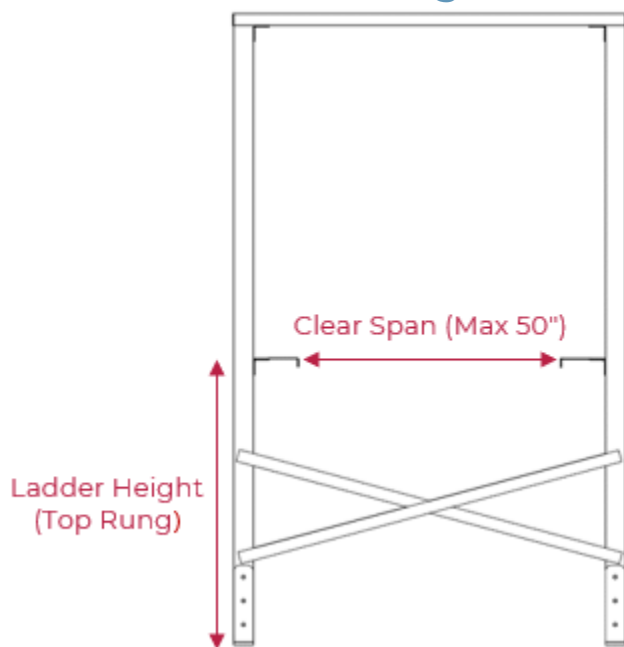

Double

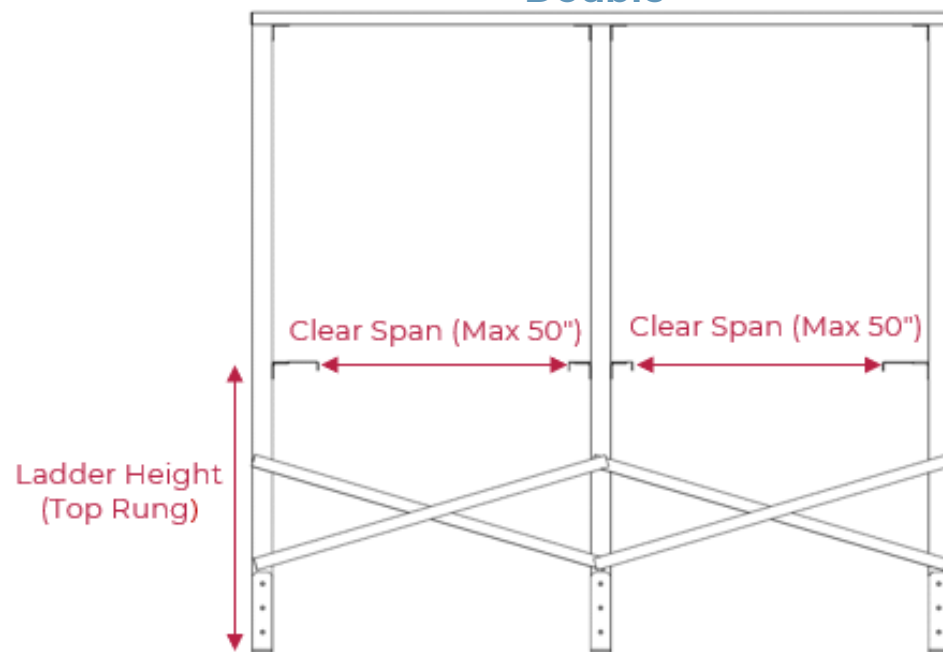

Heights

- Ladder heights delivered in 1 ft. increments (2, 3, 4, 5 ft.)
- Field cut ladders to exact height required

Spans

- Maximum of 50" clear span between top tread plates
- Field cut handrail and bracing to exact span required