

Document Name: SSI Fabrication Tolerances	DOCUMENT NO: 20053.A
	REVISION NO: 1
	REVISION DATE: 11/16/23
	PAGE NO: Page 1 of 1

Holes: 7/16", 9/16", 13/16" and 1 1/8" Holes = $\pm 1/16"$
From Design Location. (See Fig. B-1, CH-1, CS-1, COL-1)

- (This implies 1/8" Tolerance Between 2 holes.)
- Example: If design calls for 3 1/2" \varnothing - \varnothing of holes:
 - Allowable will be a Minimum of 3 3/8" to Maximum 3 5/8" \varnothing - \varnothing
- Drilled/Punched/Lasered/Plasma hole diameter by size of hole called out on drawing:
 - Standard Part Hole Tolerance: = $+1/16"$ - 0"
 - Base Plate Hole Tolerance = See Sheet 20083-BASE PLATE TOLERANCES-1100 SERIES
 - Slight coning of holes is acceptable, follow min./max. tolerance dims., ensuring top dia. of hole is desired dia.

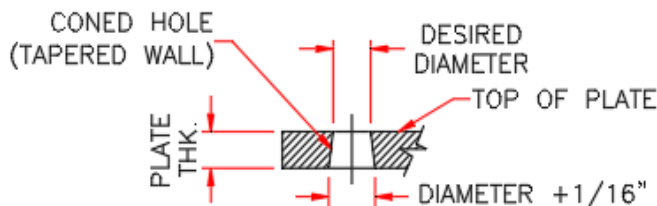

ACCEPTABLE SLIGHT CONING OF HOLES

C-Section Tolerance: (See Fig. CS-1)

- Length = $+1/16"$, - 1/8"
- Depth = $\pm 1/8"$
- 1" Return Flange Width = $\pm 1/8"$
- 2 1/2" Flange Width = $\pm 1/16"$

Catwalk Side Channel Tolerance:

- Length = $+1/16"$, - 1/8"
- Height = $\pm 1/8"$, Hold 4" Main C-Shape
- 2 3/8" Flange Width = $\pm 1/16"$
- 2" Bottom Return Flange Width = +0 -1/8"

Beam & Channel Tolerance: Length = $\pm 1/4"$
(See Fig. B-1, CH-1)

Column Tubes: Length = $\pm 1/4"$ (See Fig. COL-1)

Angles: Length = $\pm 1/16"$

Bridging Angles: = $\pm 1/4"$

Squareness: (not to exceed overall length tolerance)

- Column Tubes = End Cut to be 1/16" Out of Square Max (See Fig. COL-2)
- C-Sections = 1/8" Out of Square (See Fig. CS-2)
- Beams & Channels = 1/8" Out of Square (See B-2, CH-2)
- Stair Treads = 1/16" Out of Square (Max)

Bends:

- Bent Plates = $\pm 2^\circ$
- Round Pipe = $\pm 1^\circ$
- Tread Riser = $\pm 1^\circ$ (Full Height)

Welds:

- Fillet Weld Size $+1/16"$ - 0"
- Length $+1/2"$ - 0"
- Straightness on Stringer Handrail $\pm 1/8"$ (For-Flushness)

Plate Dimension Tolerance: $\pm 1/8"$

Coped Beam Web Flatness Tolerance:

$+1/32"$, -1/16"

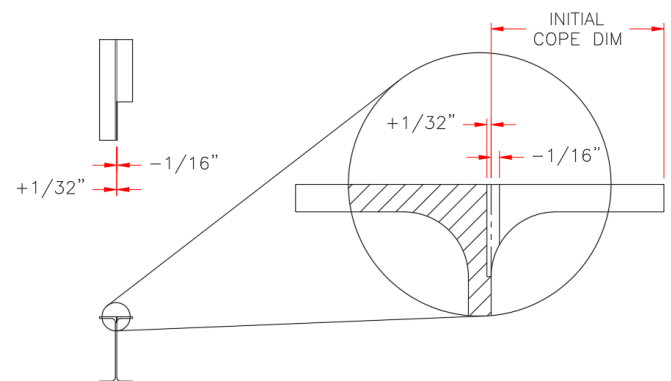

Coped Beam Radius Tolerance: $+1/4"$ -1/8"

Welded Assemblies: (Verify application, size, and B.O.M. components, and determine per situation. Use tolerances described within this document as required for individual B.O.M. items of assemblies.)