

1. SEE PROJECT DRAWINGS FOR BASE PLATE STYLES AND ORIENTATION TO MEZZ. FRAMING ABOVE.

2. BOLT C-SECTION TO CSA'S AS REQ'D.

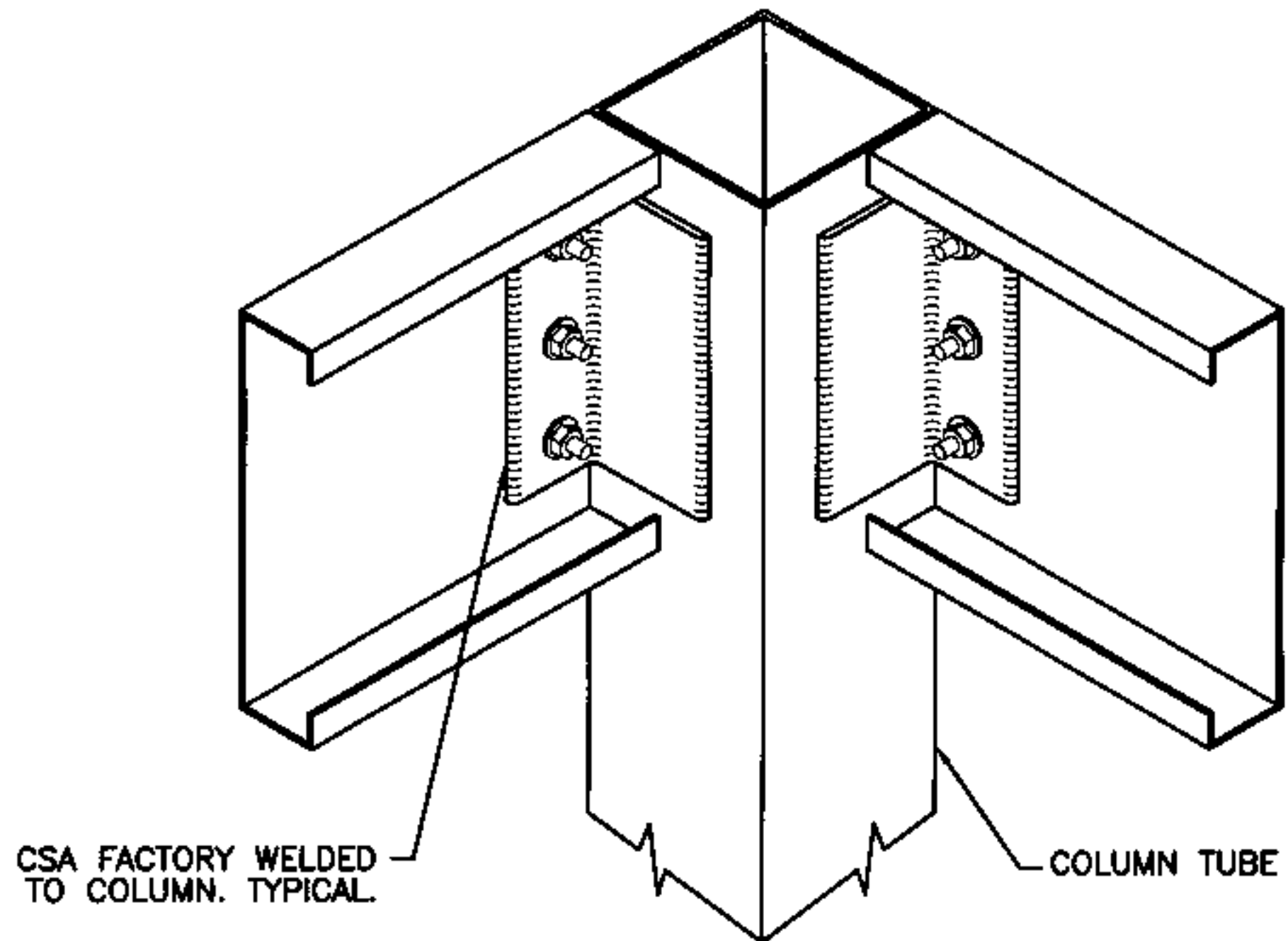

DETAIL 2